

MONTY E-Bike



DPIE 3

USER'S MANUAL

INTRODUCTION

WELCOME TO THE MONTY FAMILY

Firstly, we would like to welcome you and thank you for choosing the Monty brand

This “User’s Manual” for your new Monty electric bike (DPIE 3) contains important information and necessary to keep your bike in good condition. It has been designed so that you can enjoy of your vehicle safely, making the most of your time.

Please read this manual carefully before using your new electric bike (hereafter: DPIE 3), and save this manual for future reference. If you have any doubts or questions, please contact your authorized Monty dealer. Your DPIE 3 is fitted with a top-quality engine and a battery of long-lasting which will not require much maintenance. Its innovative design and safe construction will provide you with km. of satisfaction.

Parents or guardians should explain the contents of this manual to any minors using the DPIE 3, to ensure that they have understood its contents.

The drawings and images may not correspond exactly to your model. They are used solely to facilitate your understanding. We apologize if any part of this manual does not correspond with the precise characteristics of your DPIE 3.

At Monty, we always strive to improve our products. As such, we may incorporate other new technical components to the models or change pieces without prior notice.

Always, hand this manual to any future owner of your DPIE 3.

The Monty family is constantly innovating to offer its clients a top-quality product made from the best materials. A clear example is our new electric vehicles. They provide a new means of light and fun transport which is also ecological, silent and does not pollute. Suitable to any age by their handy and economical use. For this reason, we want to thank you for choosing us, a decision which will benefit the environment and definitely all of us.

Thank you for dedicating few minutes to read this manual. We hope to have got a product of your requirement..

For further information about our products, visit our webpage: <http://www.monty.es>



IMPORTANT WARNINGS

NON-FULFILLMENT OF THE INSTRUCTIONS DETAILED IN THIS MANUAL MAY LEAD TO MECHANICAL FAILURES, A LOSS OF CONTROL AND POSSIBLE FALLS, WITH SERIOUS PHYSICAL INJURIES TO THE USER OR OTHERS, INCLUDING EVEN DEATH

INCORRECT USAGE MAY ALSO RISK YOUR PHYSICAL INTEGRITY AND THAT OF OTHERS.

SAFETY WARNING

DO NOT OPEN OR MANIPULATE THE BATTERY, DOING SO WILL FORFEIT THE WARRANTY ESTABLISHED IN THIS MANUAL.

IF YOU OPEN OR MANIPULATE THE BATTERY, CHARGER OR ELECTRIC CIRCUIT, YOU MAY PROVOKE A SHORT-CIRCUIT AND POSSIBLE INJURIES (SHOCK OR BURNS) .

WE RECOMMEND YOU TO USE ALWAYS THE HELMET

WARRANTY ADVISES

MODIFYING THE FRAME, FORK, OR ANY OTHER COMPONENT IMPLIES THAT THIS VEHICLE NO LONGER CONFORMS TO OUR SPECIFICATIONS AND THEREFORE ANNULS THE WARRANTY.

MANIPULATING THE ELECTRIC COMPONENTS OF THE VEHICLE WILL ALSO FREE MONTY OF ANY POSSIBLE LIABILITY

SHOULD YOU HAVE ANY QUESTIONS OR DOUBTS, PLEASE CONTACT YOUR AUTHORIZED DEALER OR VISIT OUR WEBSITE:
<http://www.monty.es>





CE (European Confirming)

1. ÍNDEX

SECTION	PAG
PRESENTATION.....	3
IMPORTANT.....	4
1. ÍNDEX.....	5
2. ICONS	5
3. DPIE 3 PARTS.....	6
4. GENERAL NORMS.....	7
5. VEHICLE ASSEMBLING	7
6. USER'S GUIDE.....	8
7. VERIFICATIONS.....	10
8. ADVICES.....	11
9. SAFETY.....	11
10. MECHANICS AND MAINTENANCE	13
10.1 Wheels	13
10.2 Handlebar and Stem.....	15
10.3 Headset and Fork.....	17
10.4 Brakes.....	17
11. BATTERY AND CHARGER	20
11.1 Battery charging.....	22
12. ELECTRIC COMPONENTS.....	23
13. CLEANING.....	23
14. TECHNICAL CHARACTERISTICS	24
15. MAINTENANCE CHARTS.....	25
16. ADJUSTMENTS.....	25
17. SOLUTIONS.....	26
18. FREQUENT QUESTIONS.....	27
19. FORM.....	28
20. GUARANTEE.....	29
21. CONTACT AND DISTRIBUTORS.....	29

2. UNDERSTANDING ICONS

The following icons are in order to easy the manual understanding and to underline of the important items.

	SEE SECTION		ADVICE
	CAUTION		MAINTENANCE

3. DPIE 3 PARTS



Optional: TOW

1. THROTTLE
2. IGNITION KEY
3. SADDLE¹
4. BATTERY LEVEL
5. BRAKE LEVER
6. STEM
7. SEAT POST RELEASE¹
8. QUICK RELEASE
9. BASKET¹
10. CHARGER PLUG
11. BATTERY CAGE
12. FORK
13. SEAT SUPPORT¹
14. DISC BRAKE
15. DPIE PLATFORM
16. LATERAL WHEEL NUT
17. CHARGER SWITCH

(1) optional parts

4. GENERAL NORMS

- Please read this manual carefully before using your Monty D-PIE 3.
- Ensure that the bike works correctly before riding
- We recommend you not to change any of the D-PIE 3 technical characteristics and not to add any devices which may interfere with them.
- Recommended to use safety equipment

5. VEHICLE ASSEMBLY

The vehicle assembling shall be done in a light, level and clean place with some basic mechanic knowledge. Or you can get in touch with your distributor or with Monty in order to solve any problem.

- Components:
 - D-PIE 3 platform
 - Stem and Handlebar
 - Integrated Charger
 - Ignition key
 - User's manual
- Assembling instructions:
 1. Take out all the parts from the box and verify to be all the required items. Remove the D-PIE 3 protector cartons with care .
 2. Fit the stem to the handlebar.

OPTIONAL:

3. Assemble the seat post to the platform, placing all the fastening nuts as it is shown in the assembling scheme.



See section: **MAINTENANCE AND MECHANIM** for a right assembling.

- Charge of the battery

1. The battery must be charged on the whole before the first riding.



See section: **BATTERY AND CHARGER** for a right charge.

6. USER'S GUIDE

DESCRIPTION

DPIE 3 is a personal mobility vehicle, provided with a platform with three wheels,. The integral electric engine is set on the front Wheel in order to give traction to the vehicle and the steering through the handlebar as well, getting a great handling. One can change the direction in a small space thanks to the position of the feet as well.

TYPE OF USE FOR WHICH THIS BIKE HAS BEEN DESIGNED

MONTY DPIE 3 and their components have been designed for standard or industrial uses. Its handling is to surprise you. One shall get familiar to this vehicle in an area free of obstacles and safe and later in enclosures or areas always provided with an even ground. Incorrect usage other than the above or riding cross-county may lead to premature wear and tear, loose joints and/or component breakage, thereby causing the cyclist to possibly fall and/or injure himself/herself.

	<p>This vehicle is not recommended to children under the age of 12. This vehicle is not recommended to persons weighing more than 100 kg. This vehicle is not allowed to be run in the public means. Please check the local rules.</p>
---	---

HOW THE DPIE 3 WORKS

MONTY DPIE 3 is simple and intuitive to be used.

Steps to follow before using:

1° Connect the electric system:

Make sure the charger to be off. Turn the contact key of the right lever to the position "ON" (5), The led lights on the information panel found in the contact lever will light up, Indicating the battery charge level (4). The DPIE 3 is ready to be run. The vehicle does not produce any noise while is still

	<p>To verify the battery charge while the vehicle is running is more exact than to be stopped.</p>
---	---

2° How to move the vehicle through the throttle:

DPIE 3 is provided with a throttle (6) set to the right grip in order to initiate the move of the vehicle. If one turns opposite to the clock hands, the engine is to speed, if one turns to the clock hands, the engine is to brake. It is provided of two shifters: one short and one long (2) to be used according to ones requirements

3º How to stop or decrease the speed:

If one uses the brake lever (1), the engine assistance and the transmission are to be interrupted so one shall grip the brake lever to stop the vehicle. Remember that the DPIE 3 is only provided with a front wheel brake.

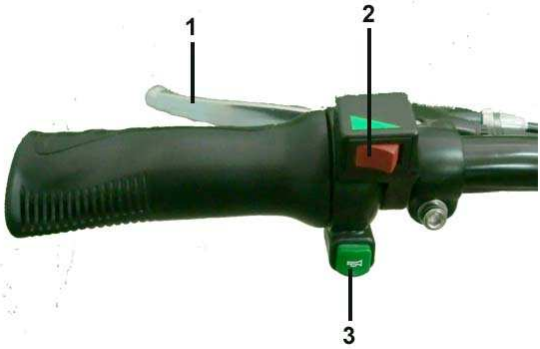
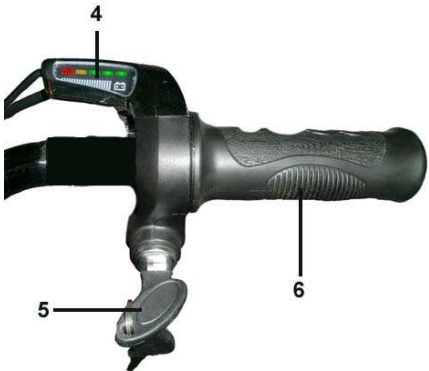
 <p>Figura 1</p>	 <p>Figura 2</p>
<p>1 BRAKE LEVER 2 SPEED INTERRUPTOR 3 HORN PUSH-BUTTON</p>	<p>4. BATTERY NIVEL INDICATOR 5. IGNITION KEY 6. THROTTLE</p>

	<p>Remember that the brake, for safety, works on the electric system, cutting the engine current.</p> <p>Important: Before using the vehicle please see the section: "VERIFICATIONS" Y "SAFETY"</p>
---	---

7. VERIFICATIONS

Check before riding for the first time

The vehicle has been verified at the Monty factory before to be on sale, Nevertheless, one should check the following components to be securely fastened before riding the DPIE 3 for the first time:

- Correct position of the front brake: lever, cable and disc.
- Correct tight of the wheel nuts.
- Correct pressure of the tires.
- Correct wheels align.
- Correct folding security system.
- Correct tight of the quick-fastening clamps.

DPIE 3 does not require any initial kind of lubrication, it is prepared to travel the first km. without any type of maintenance, afterwards, the standard maintenance.

DPIE 3 and its components shall be checked before riding. Remember that if one detect any problem which can not solved by oneself, please contact with an official dealer.



Take as usual the following checks before riding the vehicle

Verifications before riding:

- **WHEELS**
- **HANDLEBAR AND STEM**
- **HEADSET AND FORK**
- **BRAKES**
- **BATTERY AND HARGER**



It is extremely important the brakes to work correctly for one safety and that of others. Carefully check the brake system each time before riding and do not use the DPIE 3 if a problem is detected.



See section: **MECHANISM AND MAINTENANCE**

8. ADVICES

- Keep your bike clean to ensure proper functioning.

- Protect the DPIE 3 against thieves. Use a lock for more security.
- Do not overpass the allowed weight.
- Ride with care
- .



See section: **SAFETY**.

- No additional passenger is allowed on the DPIE 3. (one sole person)
- A speedometer can help to control the autonomy and maintenance of the vehicle.
- Plan your route according to the autonomy of the vehicle.
- Avoid water entering into the bearings.
- The battery must be charged in an airing area.
- A programmer by the charger plug is to help in the charger task.

9. SAFETY

DPIE 3 preventive actions

1. To brake or stop the DPIE 3, the user shall grip the brake lever rightly, depending on the circumstances and the engine is to be disconnected automatically. Bear in mind that the brake system works as follows: One shall grip the left lever to brake the front wheel.
2. DPIE 3 must be ridden by one sole person.
3. On rainy or snowy days, reduce the speed to avoid incidents.
4. Avoid riding on rainy days, days with heavy snowfall or through flooded areas.

Efficient riding.

The autonomy and performance of the DPIE 3 depend on some factors. These can be classified in two types:

- External related to the environment conditions (surface, weather, etc.).
- Internal related to the vehicle state and the running style as well.

The external factors cannot be changed but yes to select a route adapted to the characteristics of the vehicle.

The internal factors more related to the user can be adapted in order to improve the lasting of the battery and the life of the vehicle.

Advices:

- Use the short gear to move the vehicle.
- Keep the tire pressure rightly.
- Verify the wheel to turn easily and the brake not to touch to the disc.
- Keep a constant speed if it is possible.
- Do not brake the vehicle suddenly, let the vehicle to lose speed smoothly.
- Do not overload the allowed weight on the DPIE 3

DPIE 3 safety riding



As with any other activity, the use of this vehicle implies certain risks. To get the Monty DPIE 3, such risks must be assumed by the user. In no case the dealer or manufacturer are to be liable.

The riding of the DPIE 3 is different from the other vehicles by having three wheels, One front central wheels and two rear ones. This vehicle stays even on turning to the contrary from the bicycle performance. The right position in order to drive the DPIE 3 is placing the feet each side of the central covering and in front of the rear axle. The control system and the handlebar turns are effectuated by the hands. To improve the traction of the vehicle on starting one shall bent forwards. On turning, the user shall bent the body towards the inside of the turning. To brake, the action shall be made in a smooth and progressive way.



Avoid suddenly and quick turns, otherwise the vehicle can lost the balance and overturn. Extreme the precautions on the turns while the seat is used.

Not to get the body too much to the rear part of the platform, the vehicle could lost the balance and the front wheel could get up.

Not to brake abruptly the vehicle could unbalance.

Not to ride stoop, kneeling or any other form except the right one

DPIE 3 is not made to get up / get down from the kerbs or to pass obstacles. In case that one should face it, one should get down from the vehicle.

- A mechanical revision must always be done before getting on the DPIE3. Ensure that the brakes work properly
- One must get familiarized with all the components of the DPIE 3.
- It is recommended to wear a helmet to ensure greater personal safety.
- Wear always appropriate shoes to use the vehicle correctly.
- Wear reflecting or very visible clothing whenever possible. Do not use the DPIE3 to jump. Attention with the irregular surfaces
- Keep the speed under control and safe to avoid losing control of the DPIE 3.
- Never ride with earphones as they reduce your ability to hear other vehicles.
- Never carry any additional passenger. No matter to be a kid. The handling capacity and safety could be affected.
- Never load anything on the vehicle which might obstruct the vision or ability to control the DPIE 3.
- Never shall the user hold himself on another vehicle while riding.
- Not to tow or be towed by other vehicles.
- Not to ride the DPIE 3 under the influence of alcohol or drugs.
- If it is possible, do not ride in adverse meteorological conditions, such as when the visibility is low, in the dark areas or to be extremely tired.
- Never allow minors under the age of 10 years to ride the DPIE 3.



ATTENTION: Caution regarding to the intensive use

As any mechanical device , DPIE 3 is to wear down with different efforts. The different materials and components used may react differently to this daily decline. If the lasting life of a given component has been exceeded, it may suddenly break, injuring the user. The cracks, scratches or discoloration in the areas subject to intense use indicate that the component has exceeded its useful life and must therefore be replaced.

10. MECHANISM AND MAINTENANCE

10.1 WHEELS

The rims and tires are an extremely important part of the DPIE3 and they should be kept in right condition. Check the right pressure and control the wear out of the tires and the rim conditions. Make sure that the wheels are well placed and fitted.

TIRES

The tires are to be in good state and properly inflated and the tread to be neither cracked nor worn down. The drawing pattern must keep as the minimum 2 mm in order to provide good traction.

The sizes are indicated on the sides of the tires. Make sure to get the tires suitable to the rim and the type of the vehicle



ADVISE: The front tire wears down quicker than the others by the traction, avoid to slip on the starts. The feet should be placed forwards on the platform in order to get more grips.



CAUTION: When replacing a tire, make sure to be suitable to the rim and the type of the vehicle. **The DPIE 3 tires are different from the standard ones.**

Tire pressure

Tires must be inflated to the right pressure to ensure the bike works properly.

The valve is the “ Schrader” type like the ones used by the cars. To inflate the tyre, the valve shall be removed, then and place the nozzle on the valve, ensuring that no air escapes , check the pressure and place the cap back on the valve to keep it from getting dirty. If the inner tube gets flat, it is recommended to be changed not to repair it .



Remember: The maximum air pressure is indicated on the lateral tires side



The air pressure must be checked regularly

PRESSURE TABLE

Wheel	Recommended			Maximum		
	Bar	Kpa	PSI	Bar	Kpa	PSI
Front	1,0	100	15	1,4	140	20
Rear	2,0	200	30	2,0	200	30

Equivalences (approx.): 1 Bar = 100 Kpa = 14,5 PSI

Wheels removing

To remove the wheel in case of a tire getting flat or any other reason, one shall follow the following steps:

Front wheel:

Make sure that the contact is out and remove the key. Disconnect the cable connector, in case that the vehicle was provided with it. Loose the wheel axle nuts counter clockwise with a fixed key. Remind the situation of the safety washers towards the assembling. Remove the wheel in a vertical down position.

To assemble the wheel, place the wheel at its correct position. Fit the safety washers and tie the nuts clockwise. Connect the engine cable and check the brakes to work properly.

Rear wheels:

To remove the rear wheel, use a tube key suitable to the nut sizes. Loose the nut and take out the wheel.. Remind the situation of the washers and the wheels. To fit the wheels, place the washers and the wheels to their original place and order and tie the nuts



See section: **Torque value**

10.2 HANDLEBAR AND STEM

The handlebar must be centred to the stem and perpendicular to the frame..

The handlebar is fitted to the stem by a plate with 4 screws. Loose the screws to regulate the handlebar position. To fix the handlebar position in a right subsection, tight the screws in alternate cross form.

The handlebar height can not be changed.

HANDLEBAR FOLDING AND ADJUSTMENT

The folding of the DPIE3 handlebar is easy and practical. Please check the explication in order to get an easy and safety folding. Make sure that no cables are over-stretched or pinched when moving the different parts

To fold the DPIE 3 handlebar: (A) to block the handlebar. **(Figure 3)** (Stem closing system).

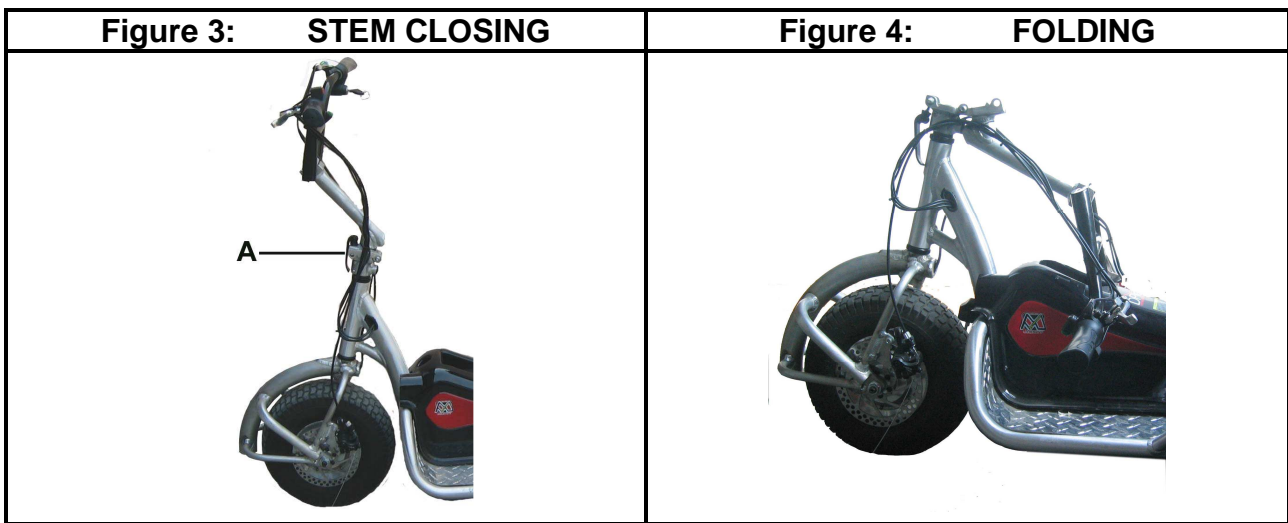

FOLDING: First pull out the closing lever (1) **(Figure 5)** (Open the closing) move the lever down and lateral to open the safety blockade. (Arrow 2) in **(Figure 6)** (unblocked closing)
 Move the stem in the rear direction. **(Figure 4)** (Folding)

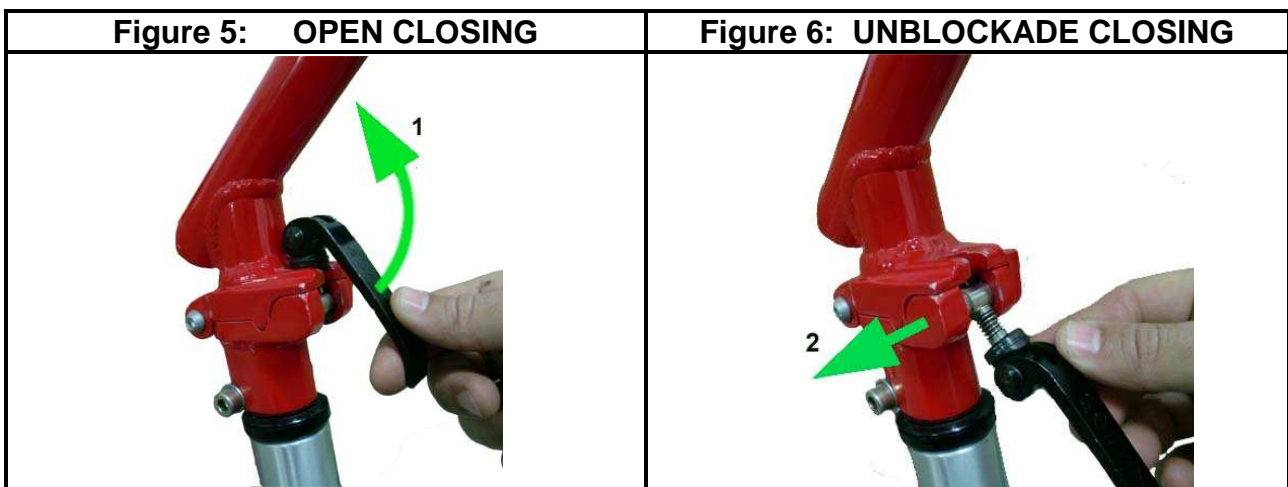

UNBLOCKADE: To ensure the stem, place it in a vertical position again, Turn the stem forwards, the safety blockade is to close automatically, later close the closing lever to the final position **(Figure 8)** (Blockade closing).
 The adjustment of the closing press can be regulated with the nut of the closing lever

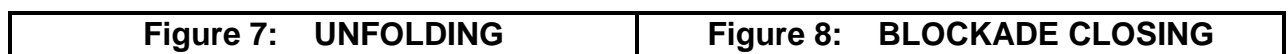

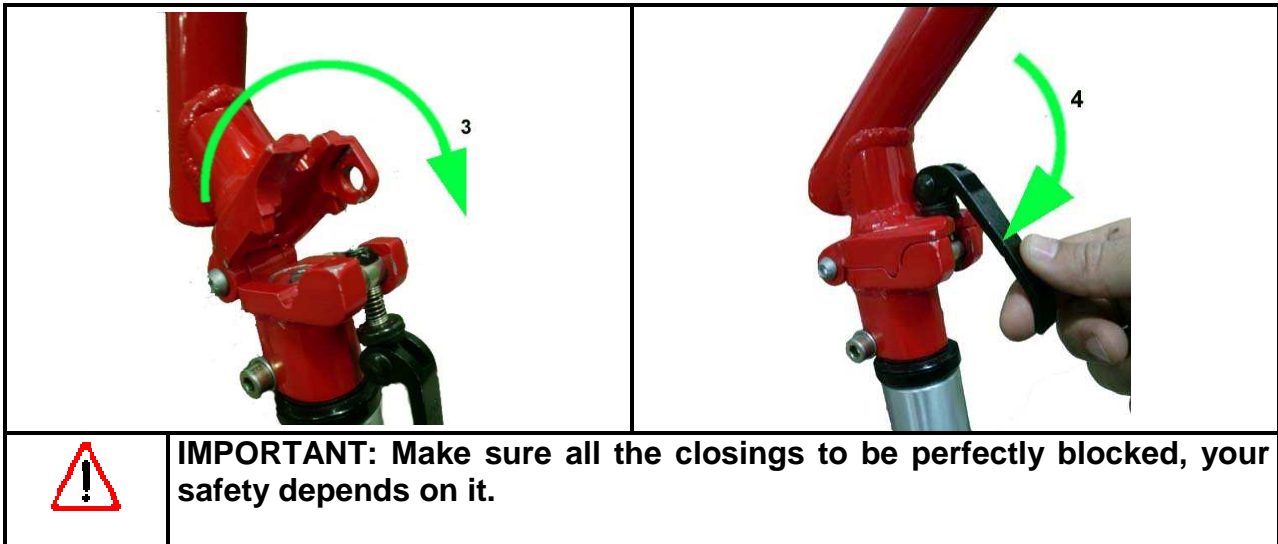

The handlebar and stem must be fitted correctly positioned and tightened in a suitable and safety position to the user.

Stem adjustment and subjection.

The stem is fitted directly to the fork tube, to make the adjustment, the lateral screws shall be loose lightly (**Figure 9**) (Lateral screws), check the headset as it is explained on the following item and tight the system again.

First, tight the central screw (**Figure 10**) (Central screw), and later the lateral screws and check the Headset.

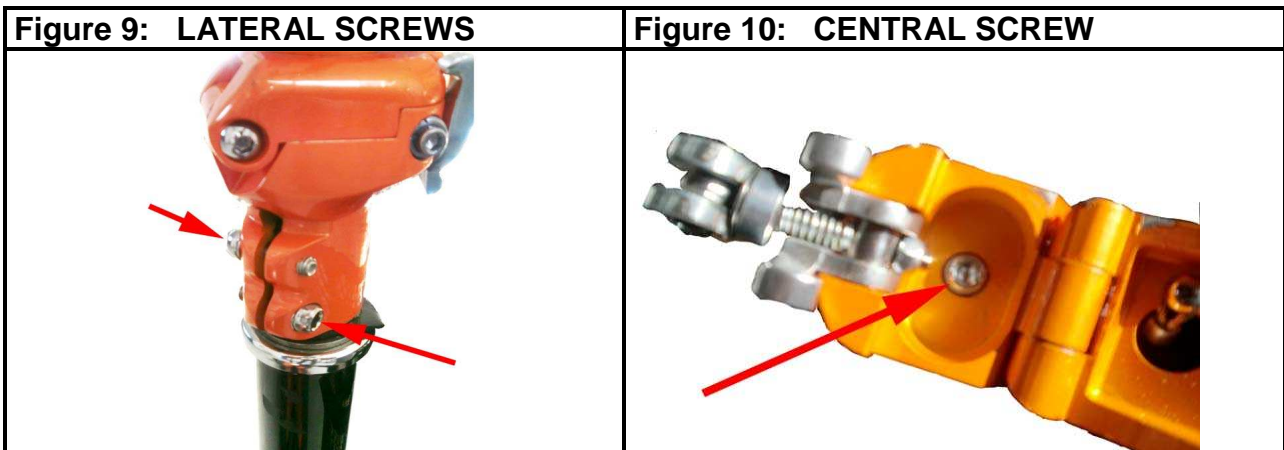

10.3 FORK AND HEADSET

The headset must turn smoothly in both sides freely and be compact on the whole.

HEADSET INSPECTION

Inspect your vehicle's headset once a month and check to make sure that it is neither too tight nor loose. If either of these is the case, do not use the bicycle and take it to your authorized dealer.

HOW TO CHECK THE PLAYS IN THE HEADSET ADJUSTMENT

Place oneself by the vehicle with the feet on the ground.

Squeeze the front brake while moving the vehicle forwards and backwards. Check if the headset is loose. The headset is formed by guards and bearings which are in contact to the frame below and above.

The handlebar and stem fitting can have a small play due to the stem holding system.

HOW TO CHECK THE HEADSET'S ADJUSTMENT

Place oneself by the vehicle with both feet on the ground. With the front wheel resting on the ground, turn the fork and handlebar from left to right and vice versa. Look, listen and feel if the headset is too tight, making a noise as turning or snagging at different points.

ADJUSTMENT

Adjusting the headset requires special tools and expertise. Please see section: **Stem adjustment and subjection**. In case of any doubt, please check it with an authorized dealer.

LUBRICACIÓN

The headset should be lubricated once a year. This requires specific know-how, expertise and special tools, for this reason only an authorized dealer should do it.



ATTENTION: An incorrect headset adjusting may cause one to lose control of the bike and fall down. Ensure that the headset and stem to be correctly fitted before each use.

10.4 BRAKES

Ensure the correct work of the brakes. DPIE3 is only provided with a sole disc brake per cable to the front wheel which allows to stop the vehicle without problems. The brakes shall work and allow the vehicle stop at a safety and proper distance. On using the brake lever, the engine is also disconnected. Check the brake shoes not to show any excessive wear.

The DPIE 3 model is fitted with a mechanical disc brake system.

The brake system of this vehicle allows getting down the speed, a very safety critic function. The following item explain how to inspect, adjust and even lubricate the DPIE 3 brakes.



CAUTION: As any braking system, an incorrect adjustment, poor maintenance, or a bad use of the brakes may cause one to lose control of the vehicle with all the consequences that this may imply. Never use the bike if the braking system is not working correctly or if you suspect any type of problem either with the brakes or their cables. If the brakes are not working correctly, one may lose control and fall down. If the DPIE 3 is not working properly, fix it or take it to an authorized dealer.

Adjusting the brake system is difficult if one does not have the necessary know-how, experience and the necessary tools. We strongly recommend that any adjustment to the brakes be carried out by an authorized dealer.

Not all brakes are compatible with all types of levers. For any brake, be sure to use only compatible levers such as those that come originally with the DPIE 3.

MECHANIC DISC BRAKE

The mechanic disc brake press the brake shoes/ pads on the disc placed on the front hub instead of pressing the pads on the rim. The disc is fitted to the axle by bolts to the left side. The brake works by a cable coming from the lever to the pincers. The brake system is formed by:

Brake lever

Brake cable & casing

Brake pincers

Brake shoes / pads.

Disc



ATTENTION: The disc brake shoes can be very hot after using them, please take care not to touch the disc on checking them.

INSPECTION

Squeeze the brake lever 5 times before riding. The levers must not touch the handlebar. Ensure that there is no oil, grease or any other matter on the disc. The disc is part of the braking system and should always be kept clean. Remove the brake shoes from the pincers for in-depth cleaning. Do not use any clean products, degreasing liquids or solvents to clean the disc. Use isopropyl alcohol.

Check once a month to ensure that the disc brakes are not worn down. If the brake pads are less than 1mm thick, they will have to be changed. Check also to ensure that the pads are correctly positioned: a distance between 0.25 and 0.75 mm from the disc when not using the brakes.. Turn the wheel while not pressing the brake lever. The pads should touch the discs as little as possible..



See section: **Torque Value**

Check your brake cables once a month to ensure that they are not twisted or rusted, that there are no broken threads or ends, and check their casings for cuts or wear. Substitute any defective piece.

ADJUSTMENT

- How to regulate the cable tension use the tensor (**T**) and fix it with the locknut
- How to adjust the separation between pad with respect to the disc:
Turn the pad's adjustment screw. (**A**). To increase the separation, turn it counter-clockwise. To reduce the distance, turn it clockwise.
How to align the brake with the disc: Loosen the brake mount bolts (**P**). Squeeze the lever completely and gradually tighten the bolts.
- How to remove the brake shoes: the pincer shall be taken out and with the fingers or thin-nosed pliers, grip the tab of the brake shoes and pull it.

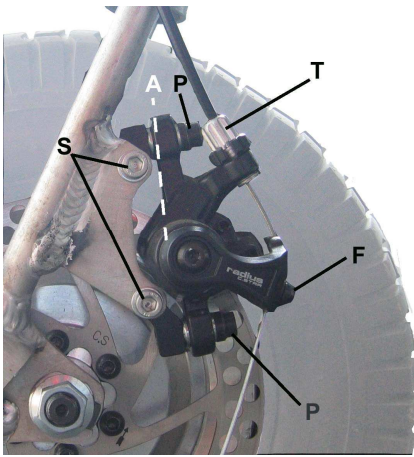

A: Adjuster nut, **(set in the inside face).**

P: Assembling bolts of the pincer

T: Tensor

F: Fitting screw cable.

S: Assembling bolts to the fork.

Figure 11

	<p>Important: The brake lever corresponds to the front Wheel.</p>
---	--

11. BATTERY AND CHARGE

The battery is one of the most important part of the DPIE 3. A correct use of the battery is to last its life.

The battery can provide 300 chargers approximately.

	<p>Very important: Do not allow children to charge the battery. The electric charge (220 v), may cause serious personal injury or even death. Do not charge the battery barefoot, on a damp or wet floor or in any conditions which might threaten your personal safety. The wall sock must meet the pertinent safety norms.</p>
---	---

GOOD USE OF THE BATTERY

The first charge of the battery is extremely important and can determine the battery's useful life. Charge the battery complete (4/6 hours approx.). The charger lights are to indicate the state of the charge.

Before using the DPIE3, the battery shall be charged before to be discharged on the whole, and will last the battery. The battery never should be run out on the whole. It does not matter the km run. Charge always the battery after having used the vehicle. In case of not using the vehicle, remember that the battery shall be charged at three or four weeks.

	Very important: Always use the charger corresponding to your model.
---	--

Any manipulation of the battery by the client will invalidate the warranty and free the manufacture of any possible liability.

Charge the battery in a well-ventilated area.

The batteries have discharge, It is normal the battery can have run out after a period of time without using it.

BATTERY AND CHARGER CHARACTERISTICS	
CHARACTERISTICS	ITEMS
Type	Lead Acid
Voltage	48 V. (12 X 4)
Capacity	12 Ah.
Lifetime (years)	2 Approx.
Number of the chargers	300 Approx.
Charge time	4-6 hours
Charger	High power
Charger (input)	115/220 VAC 60/50 Hz
Charger (output)	48 VDC
Charger fuse	10 A

BATTERY CHARGE INDICATORS

EI DPIE 3 provides a battery charge indicator on the right grip. **(Figure 12)**. This indicator has 5 light: 3 Green, 1 Orange, 1 Red. It is similar to a traffic lights.

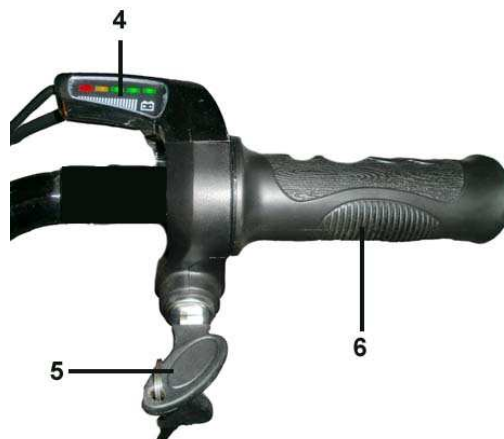

Figure 12



The indicator is more reliable while the vehicle is running. It is normal if a light goes out on starting, this means that the consumption is important.

- | | | |
|--------------------------|---------------------|----------------------------------|
| • All lights on: | Battery charged. | Ready to start |
| • Green light out | Battery to 60-70 %. | One can ride with prevision. |
| • Two Green lights out | Battery to 40-50 %. | Few charge. |
| • Three Green lights out | Battery to 10-20 %. | The battery should be charged. |
| • Only the red light | Battery discharged | The battery must be charged once |

The environmental temperature can affect the good work of the battery. In general, the battery is to work properly in high temperatures. When the temperature drops below 0° C, however, its performance can be reduced to a third. For this reason, it is probable that the charge can last less time in winter. At 20° C, the battery shall work normally. When the temperature exceeds 35°-40°C (or if the battery has been exposed to the sun for a long time), the electrical components may not work normally.

Actions which may effect or reduce the battery performance.

- Constantly starting and stopping the DPIE 3 as it can be driving in cities
- Constantly braking and turning the bike on and off
- Riding upwind or uphill and carrying extra weight
- Low pressure tire and braked wheels

These actions can influence the battery's performance, reducing its life and the distance which can travel to be shorter. We recommend to take note of the above indicated points to extend as much as possible the travelling distance that the DPIE 3 can travel .

11.1 BATTERY RECHARGING

Ensure the battery to be charged completely before using the vehicle for the first time. The battery can be to the 50% charged when one may receive the vehicle. DPIE 3 is provided with an integrated recharging system to the vehicle with an external plug in the front part (**Figure 13**) directly to the system which is retractable. On the rear part of the Central covering (**Figure 14**) there is a switch to connect the charger and two informative light led to know the level of the charge. This easy to charge the battery to any place without needing any external charger. In this way, the charger system is always ready without problems.



Figure 13



Figure 14

UTILIZATION OF THE SYSTEM

STEPS TO FOLLOW TO CHARGE THE BATTERY PROPELY:

1. Make sure the contact key to be in position "OFF".
2. Connect the plug to the electric system.
3. To initiate the charge, push the Red button from the rear side of the covering.
4. The light led indicate the position level of the charge.
5. To stop the charging, push again the Red button
6. take out the plug from the electric system



Figure 15



Figure 16

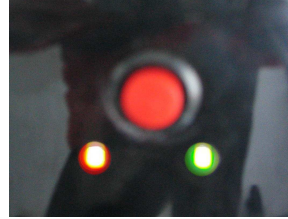

Figure 17



Figure 18

MEANING OF THE LIGHTS (LEDS):

RED LED MEANS: The charger is connected to the electric system

+ YELLOW LED : The charge is being charged (**Figure 16**)

+ GREEN LED: The battery is already charged (**Figure 17**)

+ OFF LED: The charger is disconnected (**Figure 18**)



ATENCIÓN: The charger is equipped with a safety fuse of 10A, in case that the charger did not work, check the state of the fuse and change it if it were necessary

12. ELECTRIC COMPONENTS

CONTROLLER

DPIE 3 controller is the nerve centre of the system. It consists of a small box placed under the battery compartment and where all the components are connected.

The controller receives all the necessary information from the brakes, engine, battery, etc.

The controller is responsible of the engine to work correctly and the DPIE 3 safety as well.

The controller checking/handling requires specific tools and know-how. Only an authorized dealer or the Monty plant should manipulate it.

ENGINE

DPIE 3 is provided with a top-quality, resistant engine. The engine is part of the front wheel, designed to provide a maximum service with barely any maintenance. The engine

as part of the front wheel must be firmly placed as it is explained in the section on the wheels section. Otherwise, there is a risk of a serious problem.
 Be especially careful with the engine cable which comes from the front wheel axle. Do not bend, cut or damage it in any way.

	Important: Avoid heavy hits to the front wheel and the rim as well, since the engine could be damaged.
---	---

13. CLEANING

Clean the vehicle each time after having used the vehicle. Do not delay the clean since such process can be more difficult once the mud and dirt get dried .
 Use a wet piece of cloth with water and soap to clean the vehicle, later take care to dry all the wet parts, avoiding the electric connections not to get wet.
 Do not use strong products which can deteriorate the paint, cables or rubbers. Verify the kind of product before using it.
 Do not wash your DPE3 using a high-pressure water system. The water could enter into the bearings and other parts deteriorating their effective work

	Important to use original pieces
It is extremely important to use always parts when replacing DEPIE 3 components. Not doing so may invalidate the manufacturer's warranty	

14. TECHNICAL CHARACTERISTICS

PART	CHARACTERISTICS
Engine	Front Wheel, 350 W Brushless
Battery	Lead Acid 48 V- 12 Ah
Voltaje	48 V
Max.speed	20 Km/h
Autonomy	25-35 Km
Charge time	4-6 h
Frame	Aluminium
Fork	Aluminium

Stem	Aluminium, holding type
Brakes	Front: Disc
Tires	Front: 13 x 5,00-6 Rear: 2,80/2,50-4
Weight	D-PIE 3 :38,15 Kg. Seat + seat post: 2 Kg. Seat support. 1 Kg. Basket: 0.9 Kg Tow: 6.3 Kg.
User max. weight	100 Kg.
Luggage max. weight	10 Kg.
Max. load	User+luggage (100 Kg.)
Equipment	Front basket, seat (optional)
Width	70 cm
Length	110 cm
height	98 cm
Turn dia.	110 cm

Note: The above specifications can be changed without previous notice

15. MAINTENANCE CHART

This chart reflects maximum values and may vary depending on the use given to the bike and the resulting wear of each riding style. It can also vary depending on the terrain, weather, riding style etc. .

Components	Inspection	Lubrication	replacement
Seat post	1 month	6 months	
Handlebar/Wheel alignment	1 month		
Fork / Headset	1 month	1 year	
Cables	1 month	6 months	
Brakshoes/pads	1 month		Excessive wear (<2mm)
Brake levers bolts	1 month	3months	
Brake levers	1 month	3 months	
disc brake	3 month (wear)		
Folding pivots	1 month	3 months	

16. ADJUSTMENT CHART

Part	Item	Adjust	Strenght
Wheels	Front nut	20-25 Nm	
	Rear nut	30-35 Nm	
Seat height	Quick release		100 N*
SEAT post	Quick release		100 N*
Stem ahead	Subjection screw	12-15 Nm	
	Adjust screw	10-14 Nm	
	Handlebar screw	12-15 Nm	
Brake lever clump	Fix screw	6-8Nm	
Pincer bolts		15 Nm	
Assembling adapter bolts		15 Nm	
Fitting disc bolts		5-6Nm	
Cable clump bolts		6-8Nm	

*Strength: 9,8N = 1kgf

17. SOLUTION CHART

	INCIDENCES	POSSIBLE CAUSA	SOLUTION
1º	Alter setting the battery to charge, it looks like it DID not charge.	<ol style="list-style-type: none"> The charger is not connected properly The charger does not work well The fuse is out 	<ol style="list-style-type: none"> Adjust the connections to ensure good contact. Ensure that the battery is in the right position (ON-OFF). Verify the plug. Check the charger light to be on. Contact to the technical service in case it did not blink The fuse must be changed
2º	When turning the battery key, the charge indicator does not light up	<ol style="list-style-type: none"> The battery is discharged on the whole The fuse is shorted out or not connected properly. The key switch does not work 	<ol style="list-style-type: none"> Check the battery indicator and recharge if it were necessary Check the fuse and replace if faulty (see the technical service section) <p>Verify the connections and contact technical service if faulty</p>
3º	The engine suddenly stops after moving just a few meters or when	<ol style="list-style-type: none"> The cable has been detached from the battery 	<ol style="list-style-type: none"> Check to ensure that the battery is connected properly

	climbing a not very steep hill.	2. The fuse is fused	2. Check the fuse and change it if it were necessary (see technical section)
4°	The engine stops or works irregularly after having use the vehicle continuously or on uphill climbs	<ol style="list-style-type: none"> 1. Engine overheated 2. The fuse is fused 3. The battery is discharged 4. There is an electric malfunction 	<ol style="list-style-type: none"> 1. Intensive and continuous use of the bike at maximum power may overheat the engine and its controller. In this case, wait a few minutes to let them cool down. 2. Check the fuse. See the relevant section 3. Check the battery charge. The amount consumed may be different depending on the external riding conditions. <p>Check the electric connections. See the relevant section</p>
5°	The battery has not enough autonomy	<ol style="list-style-type: none"> 1. The battery has not been charged properly 2. The battery is not recharging correctly 	<ol style="list-style-type: none"> 1. The battery has to be in top conditions to achieve the full charge autonomy established in this manual. You also have to consider that the distance you ride will vary depending on the rider's weight, the trajectory or DPIE3 conditions 2. contact to a technical service
6°	A strange noise can be hear for the front wheel (engine)	<ol style="list-style-type: none"> 1. The wheel is not aligned properly 2. The spokes can be loose 3. The engine gears are worn 	<ol style="list-style-type: none"> 1. Check the alignment of the wheel . 2. Tight the spokes 3. The bearings in models without brushless engine may wear out. In this case, contact an authorised dealer to replace them.
7°	The brakes make noise or/ they do not brake very well	<ol style="list-style-type: none"> 1. the bike is still brand new. It needs a little running 2. The brakes are not aligned 3. The brake levers can not be tightened properly 4. The brake shoes are worn 	<ol style="list-style-type: none"> 1. It is normal in a new bike for brakes to make some noise. If after a few days of use the, noise persists, check the brakes to be aligned 2. Place the brakes in the right position (see the relevant section) 3. Check the lever tension by means of a regulator 4. Check the brake pads and replace them it were necessary

18. FREQUENT ASKED QUESTIONS

Can the DPIE3 be washed with water?

Yes, but we especial care, mainly in the areas with electric connections. Do not wash using a high water pressure system.

Is it possible to run in the rain?

Yes, if it is not raining hard. Avoid to pass through puddles or wet areas

Can the DPIE 3 be let out?

We recommend to protect the vehicle and store it in a covered area, mainly in the coastal areas

What happens if the DPIE 3 has not been used for a long time?

The maintenance of the battery shall be made even if the vehicle is not used.

19. CLIENT CONTACT FORM

Dear Client,

If you want to be kept up-to-date on the latest Monty electrical products, including everything related to the World of the E-bikes, send an e-mail with the following information to: E-bike@monty.es:

Name:

Address:

Zip code:

Town:

Country:

Telephone number:

e- mail address:

Model purchased:

Purchase date:

Place of purchase (Shop or authorized dealer)

or this information can be send by post to:

BICICLETAS MONTY, S.A.

DPTO. E-BIKE

C/ INDUSTRIA, 30-32

08980 SANT FELIU DE LLOBREGAT

BARCELONA – SPAIN –

20. Guarantee

A warranty is established through the vendor in accordance with the law 232003, dated 10 July, from the consumer sale warranties, and in accordance with the Directive 1999/44CE.

Additional conditions:

The warranty does not cover the DPIE3 parts subjected to normal wear, such as tires, chain, brakes, cables etc.

The battery and charger are covered by a guarantee as follow: Lead-Acid battery: 6 months and Li-ion (Lithium) battery: 1 year

Never use any other manufacturer's components. Never repair the DPIE 3 by oneself. Take it to the store where the vehicle was purchased or to an authorized Monty dealer. In case this stipulation was not respected and in case of any problem or accident, Monty shall not assume any responsibility nor be held liable, and this warranty shall be rescinded.

Modifying the frame, fork or any other component implies that the DPIE3 no longer conforms to our specifications, thereby annulling this warranty.

21. INFORMATION CONTACT AND DEALERS

We recommend to get in touch with the dealer where the vehicle was purchased in case of any doubt or problem..

For more information::

- Monty web site, www.monty.es
- By e-mail: e-bike@monty.es
- By telephone: : **93.632.59.89**

We thank you for having dedicated some time to read this manual in order to improve the use of the new DPIE 3. We thank you , as well, for any point of view from your side.

Edition: 02/2010
Revision: 02/2010
Ref: 3'10